

**Spring Cable Reel (SCR)**  
C BEF263616-15-E-RLS-S

---

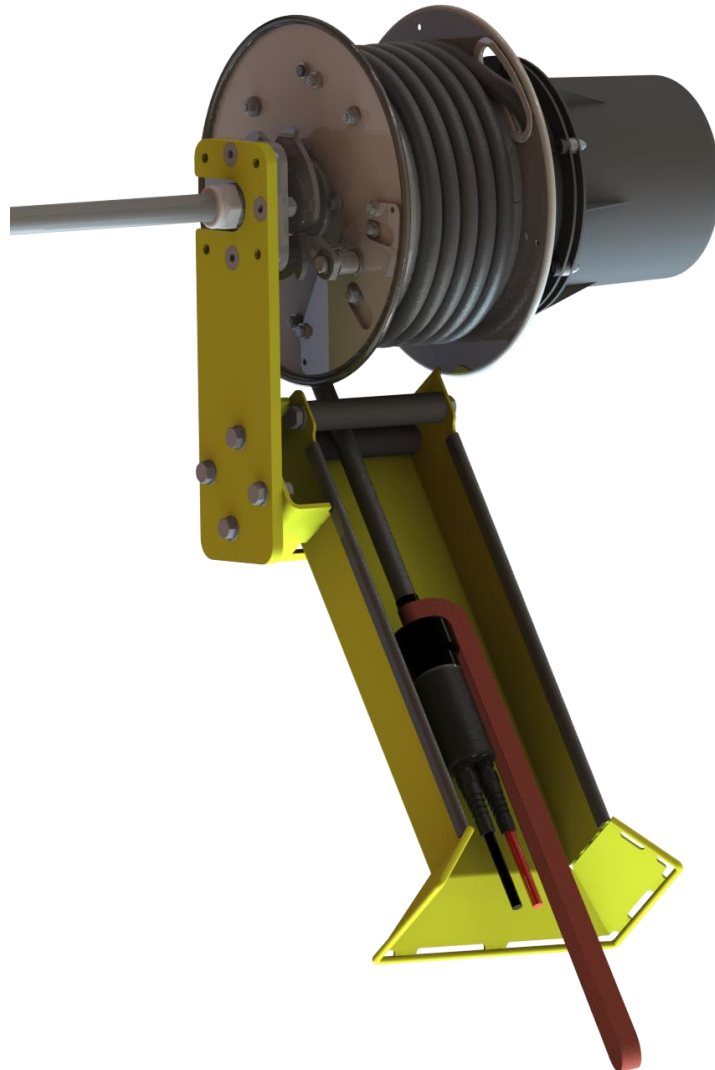

## Spring Cable Reel (SCR) C BEF263616-15-E-RLS-S

---

### Contents

<b>1</b>	<b>Safety rules</b> .....	<b>3</b>
1.1	Intended use .....	4
1.2	Improper use .....	4
1.3	Other applicable documents .....	4
<b>2</b>	<b>Terminology</b> .....	<b>5</b>
<b>3</b>	<b>Commissioning</b> .....	<b>6</b>
3.1	Mechanical attachment .....	6
3.2	Electrical installation .....	8
3.2.1	PVC control cable 3x0.75mm <sup>2</sup> for limit switches, flange side .....	8
3.2.2	Energy cable .....	8
3.3	Setting the limit switches .....	9
<b>4</b>	<b>Operation</b> .....	<b>11</b>
4.1	Have workers operate the spring cable reel (SCR) .....	11
4.1.1	Disconnecting the energy cable .....	11
4.1.2	Winding the energy cable .....	11
<b>5</b>	<b>Service</b> .....	<b>12</b>
5.1	Safety .....	12
5.2	Service intervals and maintenance work .....	12
5.2.1	Changing the red/black vehicle connection cables (2x25mm <sup>2</sup> ) .....	13
5.2.2	Replacing the reel cable .....	14
<b>6</b>	<b>Index</b> .....	<b>17</b>

## Spring Cable Reel (SCR) C BEF263616-15-E-RLS-S

---

### 1 Safety rules

---

Safety and hazard information is identified in these assembly instructions by symbols. Safety instructions are introduced by signal words that signal the scale of the hazard. Always observe safety and hazard instructions, and work carefully to avoid accidents, bodily injury and damage to property!



**DANGER!**

... indicates an immediately hazardous situation, which if not avoided, may result in death or serious injury.



**DANGER!**

... indicates an immediately hazardous situation due to electricity, which if not avoided, may result in death or serious injury.



**WARNING!**

... indicates a possibly hazardous situation, which if not avoided, may result in death or serious injury.



**WARNING!**

... indicates a possibly hazardous situation due to electricity, which if not avoided, may result in death or serious injury.



**CAUTION!**

... indicates a possibly hazardous situation, which if not avoided, may result in moderate or minor injury.



#### **Tips and recommendations:**

...refers to useful tips and recommendations as well as information for efficient and trouble-free operation.



**CAUTION!**

...indicates measures that help avoid property damage.

## Spring Cable Reel (SCR) C BEF263616-15-E-RLS-S

---

### 1.1 Intended use

- The spring cable reel (SCR) is intended for the 12 VDC external power supply of vehicles during the production sequence.
- The SCR is installed on a load-handling device (LHD) or on the loading device carrier.
- The SCR is always mounted in the the axis position.
- Operation of a SCR is manual and carried out by the worker; the cable is manually pulled and returned.

### 1.2 Improper use

Improper use is any use other than those listed in 1.1.

Use for any purpose other than or in addition to the intended use is permitted only after discussion with the manufacturer.

### 1.3 Other applicable documents

This installation manual applies to SCR units with flange-mounted cable funnels as well as customer-specific parts. Please also note the following documents:

#### Additional Documents:

- Declaration of incorporation
- Dimensional drawings MZ61-F70-0431
- Replacement parts list EL61-F070-0431

#### Applicable documents:

- MAL6100-0001 Spring cable reel BEF150 - BEF500
- BAL6100-0001 Handling recommendations for drive springs

**Spring Cable Reel (SCR)**  
C BEF263616-15-E-RLS-S

**2 Terminology**

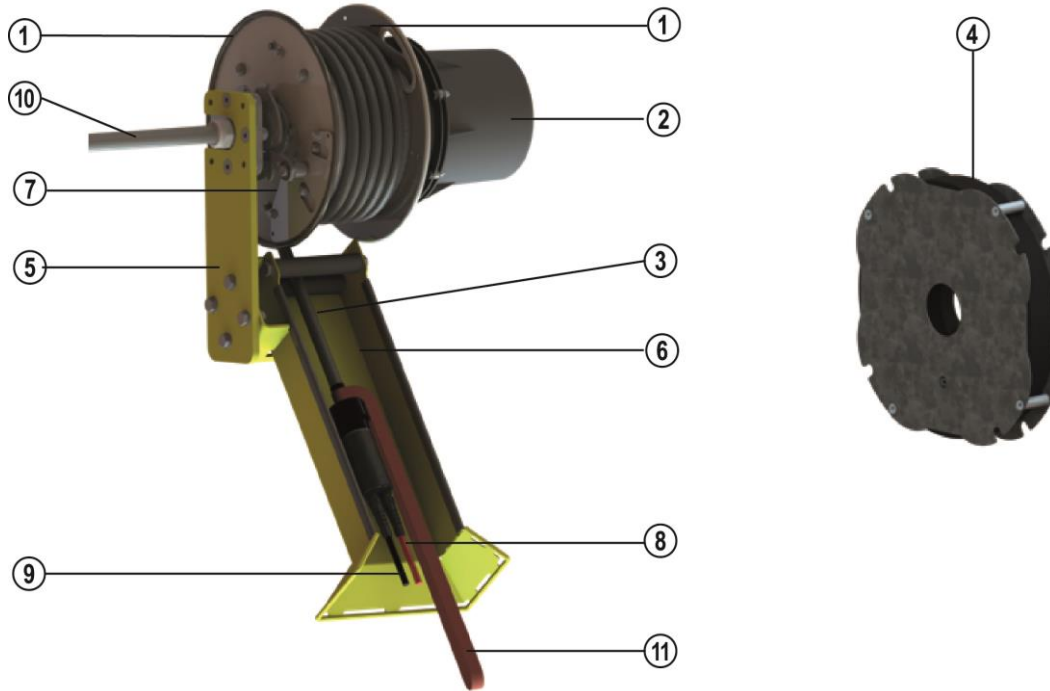

Fig. 1: Main assemblies of the SCR

Item	Name
1	End flange, both sides
2	Slip ring assembly (SRA), housing with type plate
3	Energy cable on vehicle side
4	Coil spring with protective housing
5	Fastening flange
6	Cable funnels
7	Locking device
8	Vehicle connection cables, red
9	Vehicle connection cables, black
10	Connection cables on flange side for energy/limit switch
11	Hand loop



Uncoiling orientation: Right (looking towards the SRA housing: in clockwise direction)

## Spring Cable Reel (SCR) C BEF263616-15-E-RLS-S

### 3 Commissioning



Commissioning may only be carried out by an electrician.

**CAUTION!**

#### 3.1 Mechanical attachment

The unit must be mechanically attached to a stable connection point with adequate load capacity.

**The mass of the reel and the forces resulting from pulling the cable out:**

- Mass of reel with cables: 51 kg
- Max. cable run: 10 N

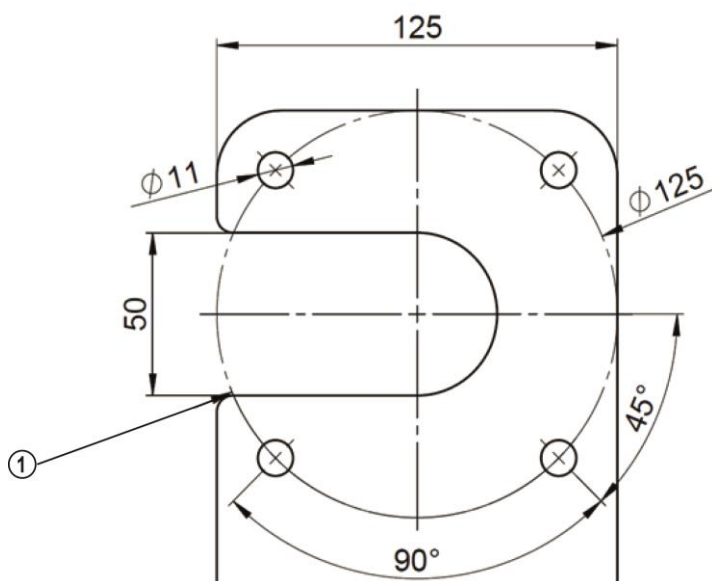

Fig. 2 Drill pattern

1 = cutout for cable collar

**During installation, please note:**

- The axis of the spring cable reel must always be positioned horizontally.
- Screws to be used: M10 screws (4), hardness class 8.8 or higher. Tightening torque: 24 Nm
- The screw attachment surface must be flat.
- Use a mounting flange matching the drilling pattern (see Fig. 2). The cutout (50 mm) is required for the cable collar.

Spring Cable Reel (SCR)  
C BEF263616-15-E-RLS-S

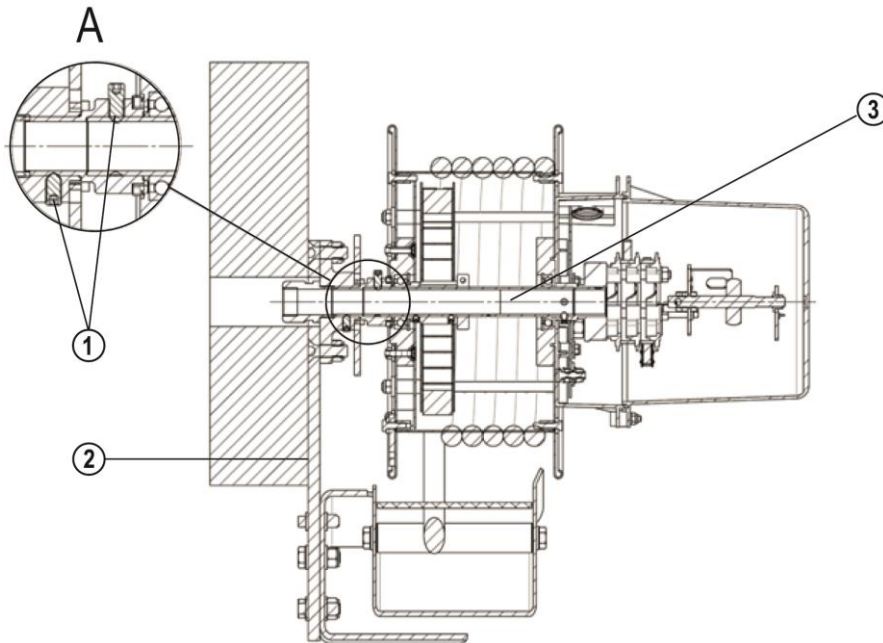

Fig. 3 Fastening flange for reel axis

Item	Name
1	Threaded pin
2	Screw attachment surface flat
3	Axis horizontal



**Note reel fastening!**

The threaded pin for attaching the flange (detail A, Fig. 3) must engage in the depression in the axis. The threaded pin is secured at the factory against loosening.

- Do not loosen the threaded pins, secure them again when is screwed back in.  
Recommended screw securing: Loctite 243

**Spring Cable Reel (SCR)**  
**C BEF263616-15-E-RLS-S**

**3.2 Electrical installation**

**3.2.1 PVC control cable 3x0.75mm<sup>2</sup> for limit switches, flange side**

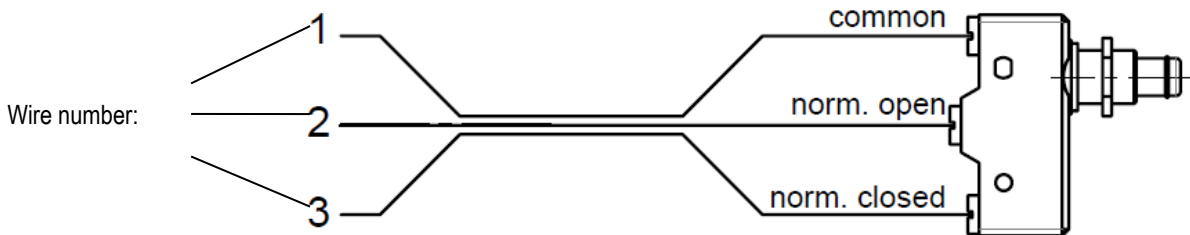

Fig. 4: PVC control cable for limit switches (flange side)

Operation of the limit switch is only permitted with control voltages ≤ 48 VDC. Max. current through end switch: 15 A

**3.2.2 Energy cable**

- Energy cable on flange side: SXV 2x16mm<sup>2</sup>
- Energy cable on vehicle side: RXP 4X16mm<sup>2</sup>
- Vehicle connection cable, red: SXV 1x25mm<sup>2</sup> red
- Vehicle connection cable, black: SXV 1x25mm<sup>2</sup> black

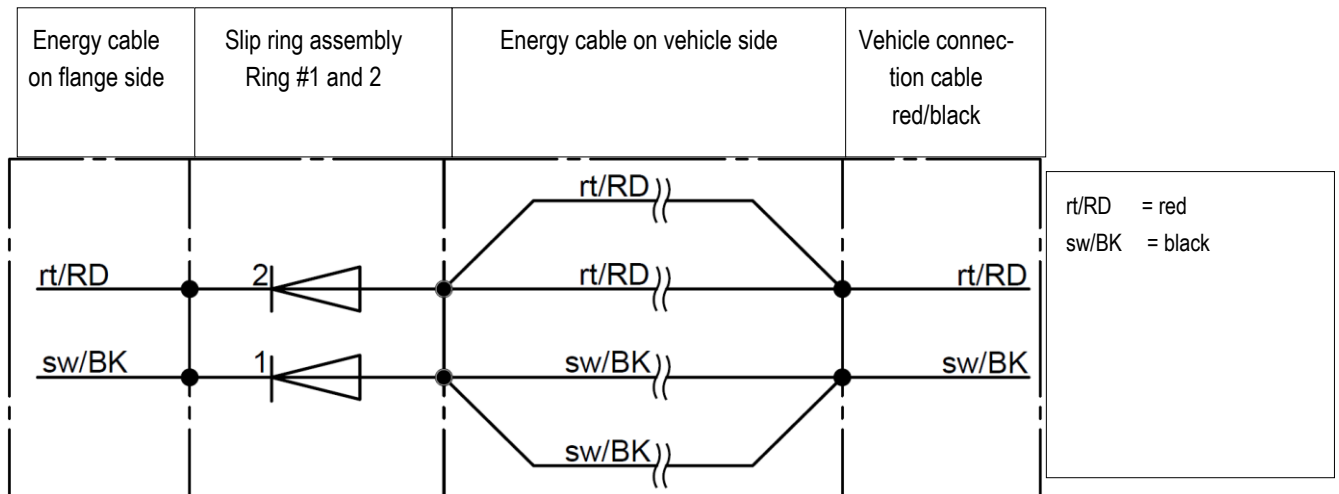

Fig. 5: Energy cable and vehicle connection cable



## Spring Cable Reel (SCR) C BEF263616-15-E-RLS-S

### 3.3 Setting the limit switches

The limit switch is preconfigured at the factory to the shutoff position in Fig. 6.

→ After changing the reelable cable, check the setting of the limit switch and adjust if necessary.



#### Danger of death by electrical shock!

Contact with components carrying electrical power can lead to death by electrocution or severe injury. Danger of injury due to shock reactions, falling, or being thrown away due to electrical shock.

- Before starting electrical connection work, **disconnect all relevant cables from power and secure the device or system against being turned back on**
- Follow the 5 safety rules!
- Ground on the **ground connection (PE)** of the slip ring assembly!

→ Pull out the reel cable about 200 mm so that the cable housing lies in the cable funnel as shown in Fig. 6. Secure the reel against winding.

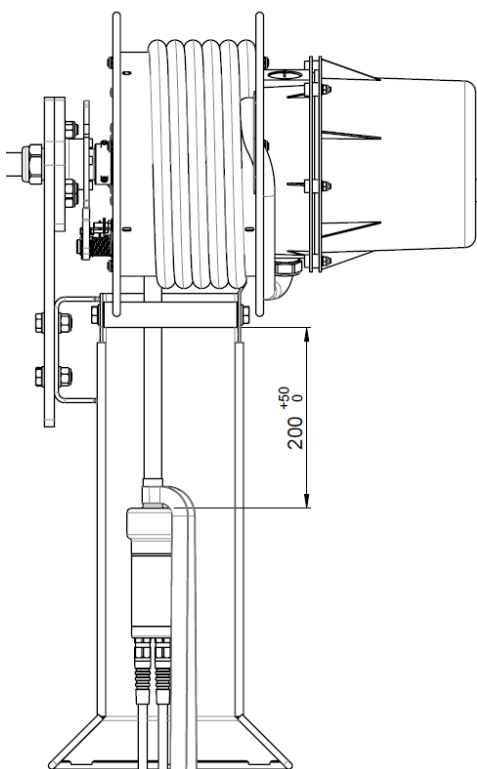

Fig. 6: Shutoff position of limit switches

- Loosen the next nuts on the slip ring assembly (SRA) housing.
- Remove the SRA hub
- Loosen the nut (1) on the limit switch (2).
- Push the limit switch (2) so that the spindle nut (3) coming from the slip ring assembly (SRA) switches the end limit switch.

## Spring Cable Reel (SCR) C BEF263616-15-E-RLS-S

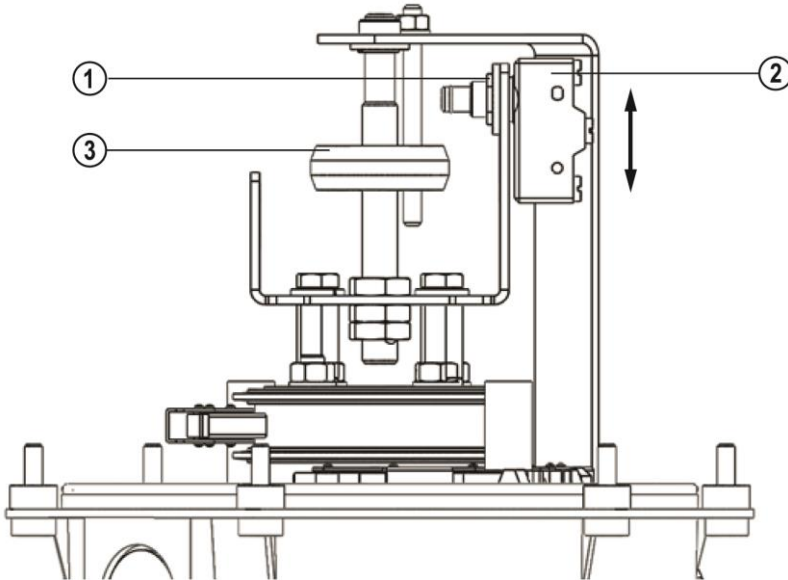

Fig. 7: Setting the limit switches

Item	Name
1	Nut
2	End limit switch
3	Spindle nut

- Unwind and then rewind the cable. Check shutoff position according to Fig. 6, repeat adjustment procedure if necessary.
- Tighten nut (1) on limit switch (2).
- Mount SRA hub again. Be sure the seal is seated properly.
- Mount the nuts on the SRA hood again, using new DIN985 M6 nuts. Tightening torque: Max. 10 Nm
- Connect the control voltage and check the function of the limit switch.

## Spring Cable Reel (SCR) C BEF263616-15-E-RLS-S

---

### 4 Operation

---



See also Chapter 8 in MAL6100-0001!



#### **WARNING!**

#### **Do not twist cable during operation!**

The cable must not be installed in such a way that it can twist around its lengthwise axis. This will destroy the cable.

- Check the winding behaviour of the reel at regular, short intervals
- Replace defective cables and set up the application in such a way that cables only wind straight

### 4.1 Have workers operate the spring cable reel (SCR)

#### 4.1.1 Disconnecting the energy cable

- The worker pulls the energy cable to the connection point of the vehicle using the hand loop.
- When the tension on the hand loop is released, the return block of the SRC engages and the cable remains in its extended position.



#### **WARNING!**

#### **Do not pull out cable fully!**

The cable may not be pulled out fully. At least two windings must remain on the reel body. Otherwise the spring and cable may be damaged.

- The red/black vehicle connection cables are connected according to the specifications of the system operator; this is not covered by this guideline.

#### 4.1.2 Winding the energy cable

- Connect the red/black vehicle connection cables to the vehicle according to the specifications of the operator.
- The worker unlocks the return block by pulling on the manual loop.
- The SRC generates a winding torque, the worker uses the manual loop to guide the energy cable back into the cable funnel to the mechanical stop.



#### **WARNING!**

#### **Do not allow the cable to snap back!**

The cable must be guided back by hand using the manual loop. The cable and reel can otherwise be damaged or destroyed.

## Spring Cable Reel (SCR) C BEF263616-15-E-RLS-S

---

### 5 Service

---

#### 5.1 Safety



**WARNING!**

##### **Danger of death by electrical shock!**

Contact with components carrying electrical power can lead to death by electrocution or severe injury. Danger of injury due to shock reactions, falling, or being thrown away due to electrical shock.

- Before starting electrical connection work, **disconnect all relevant cables from power and secure the device or system against being turned back on**
- Follow the 5 safety rules!
- Ground on the **ground connection** (PE) of the slip ring assembly!

#### 5.2 Service intervals and maintenance work



Carry out general maintenance work on the SRC according to Chapter 9 of MAL6100-0001!

## Spring Cable Reel (SCR) C BEF263616-15-E-RLS-S

### 5.2.1 Changing the red/black vehicle connection cables (2x25mm<sup>2</sup>)

The red/black vehicle connection cables are delivered fully assembled as a replacement part set. See EL61-F070-0431 for more information.

- Loosen kink prevention screw connectors (1) on the 25 mm<sup>2</sup> wires.
- Loosen screws (2) in housing cover (3).
- Remove housing cover (3).
- Remove housing pipe (4).
- Loosen nuts (5) to dismount the red/black vehicle connection cables (6 and 7).

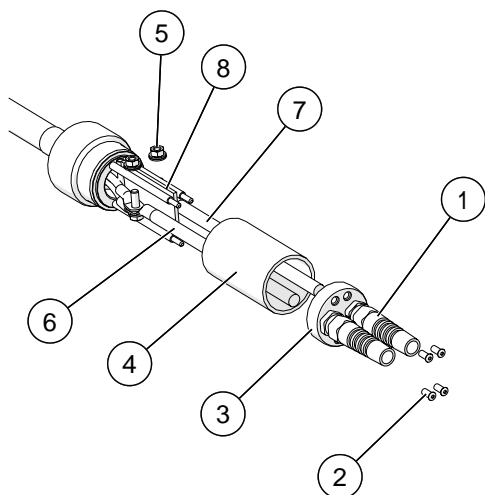

Fig. 8: Exploded view of cable

Item	Name
1	Kink protection screw connectors
2	Screws
3	Housing cover
4	Housing pipe
5	Nuts
6	Red vehicle connection cable
7	Black vehicle connection cable
8	Separator plate

- Thread the new red/black vehicle connection cables (6, 7) through the kink prevention connectors (1), housing cover (3) and housing pipe (4).
- Connect the ring cable shows of the red/black vehicle connection cables to those of the energy cable according to Chapter 3.2.2 .
- Tighten nuts (5). Tightening torque: 7 Nm
- Check polarity!

## Spring Cable Reel (SCR) C BEF263616-15-E-RLS-S



**WARNING!**

### **Danger of death by electrical shock!**

Contact with components carrying electrical power can lead to death by electrocution or severe injury. Danger of injury due to shock reactions, falling, or being thrown away due to electrical shock.

- Before starting electrical connection work, **disconnect all relevant cables from power and secure the device or system against being turned back on**
- Follow the 5 safety rules!
- Ground on the **ground connection** (PE) of the slip ring assembly!

→ Mount the housing pipe (4) and housing cover (3) again.

→ Tighten screws (2) in the cover (3).

→ Tighten kink prevention screw connections (1) again.

### 5.2.2 Replacing the reel cable



**DANGER!**

### **Danger of death by electrical shock!**

Contact with components carrying electrical power can lead to death by electrocution or severe injury. Danger of injury due to shock reactions, falling, or being thrown away due to electrical shock.

- Before starting electrical connection work, **disconnect all relevant cables from power and secure the device or system against being turned back on**
- Follow the five safety rules!
- Ground on the **ground connection** (PE) of the slip ring assembly!



**DANGER!**

### **Danger of pretensioned drive springs!**

Reel is pretensioned!

- Before starting dismantling of the cable/guide rollers/funnel, save the reel against torsion!



**WARNING!**

### **Note before turning on!**

- Before the device or system is started, test the insulation resistance according to locally applicable technical standards, directives, and law
- Carry out the electrical tests appropriate to your country according to the customer's usual procedures



**WARNING!**

### **Attach tension relief!**

- To avoid damage to the cables, always provide sufficient tension relief



Carry out electrical installation after mechanical attachment is complete.

## Spring Cable Reel (SCR) C BEF263616-15-E-RLS-S

- Remove the slip ring assembly (SRA) hub.
- Loose cable shoes from current collectors (M6 thread).

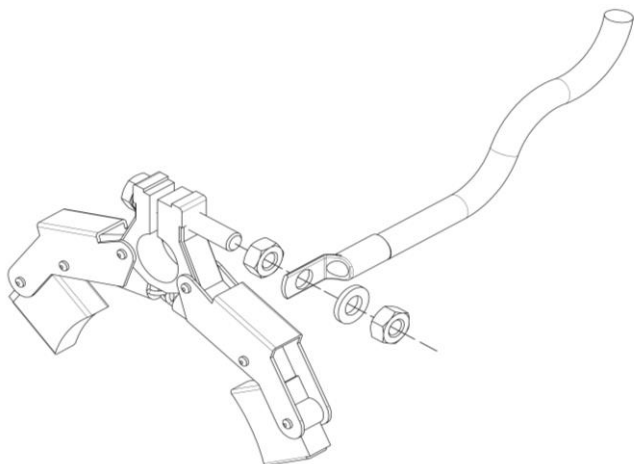

Fig. 9: Connecting current collector type 15

- Open cable collar (1) and pull the cable out.

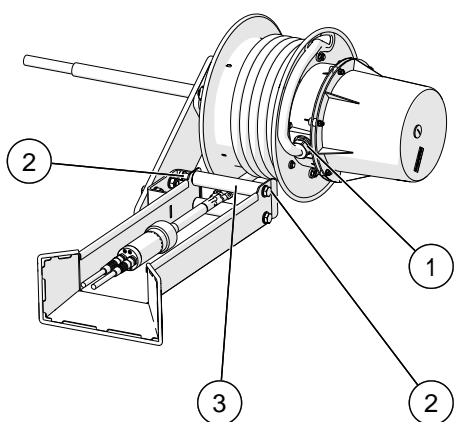

Fig. 10 Remove the guide rollers

Item	Name
1	Cable collar
2	Screws
3	Upper guide roller

- Secure the reel against turning! Reel is pretensioned!
- Loose screws (2) and remove the upper guide roller (3)
- Unwind the cable from the reel.
- Guide the new cable through the slot in the outer round plate and the cable collar (1) into the bottom part of the hub (SRA).
- Connect the reel cable to the current collectors of the slip ring assembly (SRA) (see Fig. 10).

## Spring Cable Reel (SCR) C BEF263616-15-E-RLS-S

---

- See chapter 3.2.2 for the conclusion.
- The cable may not contact the slip ring assembly within the slip ring assembly housing!
- Tighten the cable collar (1) to relieve tension.
- Wind the reel cable by hand without twisting it, and tie the cable end onto the reel.
- Pretension the reel with 4 turns in the take-off direction and secure against turning back!
- Loosen the end of the mobile cable and unwind enough cable manually (= one turn per drum) that the cable housing stops in the middle of the cable funnel.
- Install the upper guide roller (3) and screws (2).
- Remove the protection against unwinding and release the spring tension carefully.
- Check for correct cable seat: The plus pole of the charger must be attached to the red vehicle connection cable, and ground on the black vehicle connection line.
- Check whether unwinding works (= check the unwinding function).



### WARNING!

#### Danger of death by electrical shock!

Contact with components carrying electrical power can lead to death by electrocution or severe injury. Danger of injury due to shock reactions, falling, or being thrown away due to electrical shock.

- Before starting electrical connection work, **disconnect all relevant cables from power and secure the device or system against being turned back on**
- Follow the 5 safety rules!
- Ground on the **ground connection** (PE) of the slip ring assembly!



### DANGER!

#### Danger of injury if cable breaks!

If the spring set is tightened until it blocks, the cable can tear off (cable break) because excessive forces are exerted on the cable. This can lead to extreme property damage and injury or even death!

- During installation, please be sure that **at least two reserve windings** are left when the mobile attachment point is at its maximum distance (complete cable unwinding)
- Never wind the spring set to its blocking point

- Adjust the limit switch (see section 3.3).



**Spring Cable Reel (SCR)**  
**C BEF263616-15-E-RLS-S**

---

**6 Index**

---

Commissioning.....	6	Operation .....	11
Disconnecting the energy cable .....	11	Other applicable documents .....	4
Electrical installation .....	8	Replacing the reel cable.....	14
Energy cable .....	8	Safety .....	12
Improper use .....	4	Safety instructions.....	3
Intended use.....	4	Service .....	12
Main assemblies.....	5	Service interval and maintenance work .....	12
Mechanical attachment .....	6	Setting the limit switches.....	9
Operating the SCR .....	11	Winding the energy cable.....	11

**Conductix-Wampfler GmbH**  
Rheinstrasse 27 + 33  
79576 Weil am Rhein - Märkt  
Germany

Phone: +49 (0) 7621 662-0  
Fax: +49 (0) 7621 662-144  
info.de@conductix.com  
www.conductix.com